

Space: the final frontier.
Above us. Around us. Within us.
We have always looked to the stars
to discover who we are.

– Michael Burnham in *Star Trek: Discovery* S2:E1

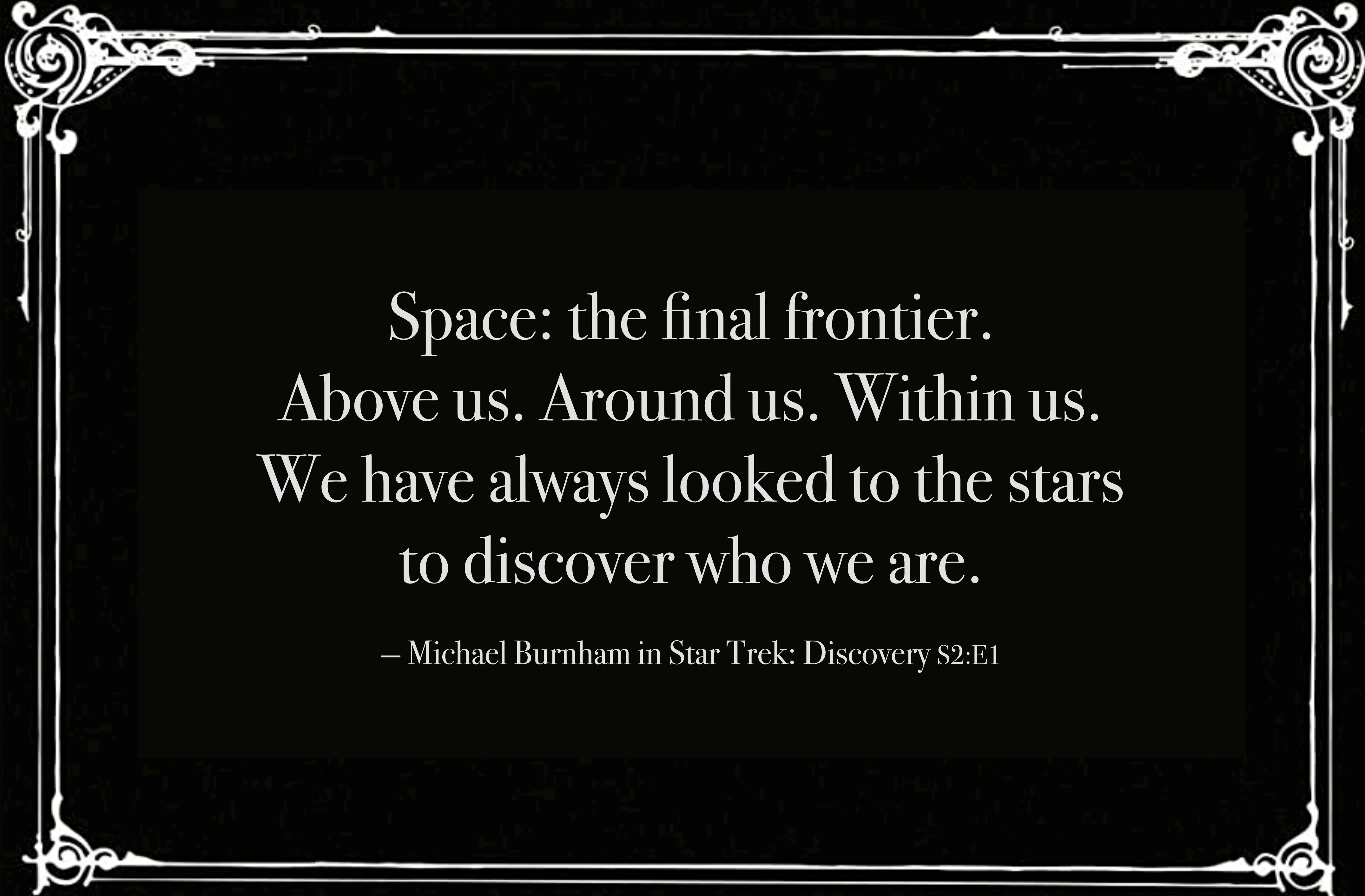

Space: the final frontier.
Above us. Around us. Within us.
We have always looked to the stars
to discover who we are.

– Michael Burnham in *Star Trek: Discovery* S2:E1

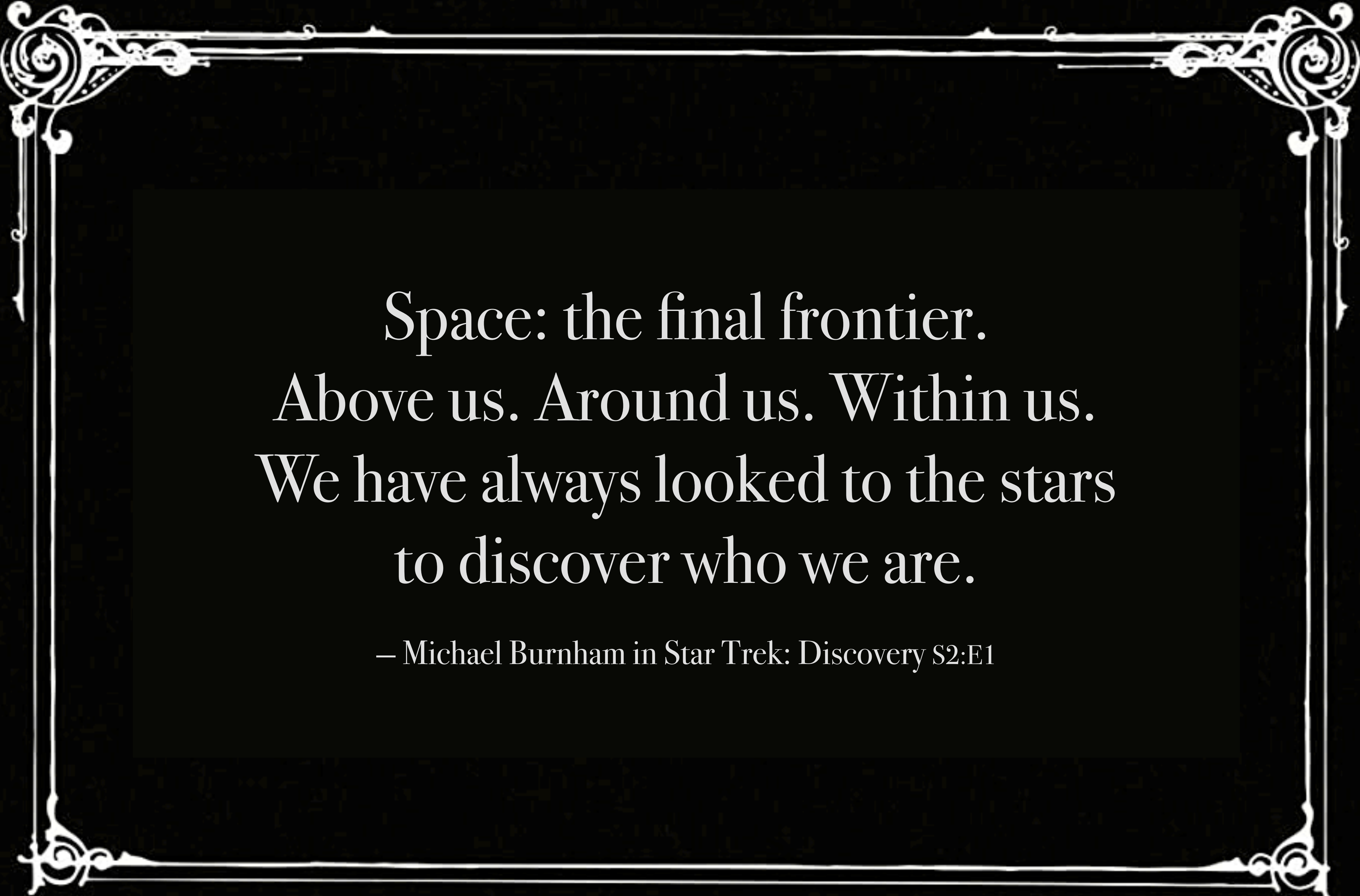

Space: the final frontier.
Above us. Around us. Within us.
We have always looked to the stars
to discover who we are.

– Michael Burnham in *Star Trek: Discovery* S2:E1



What a
kerning!



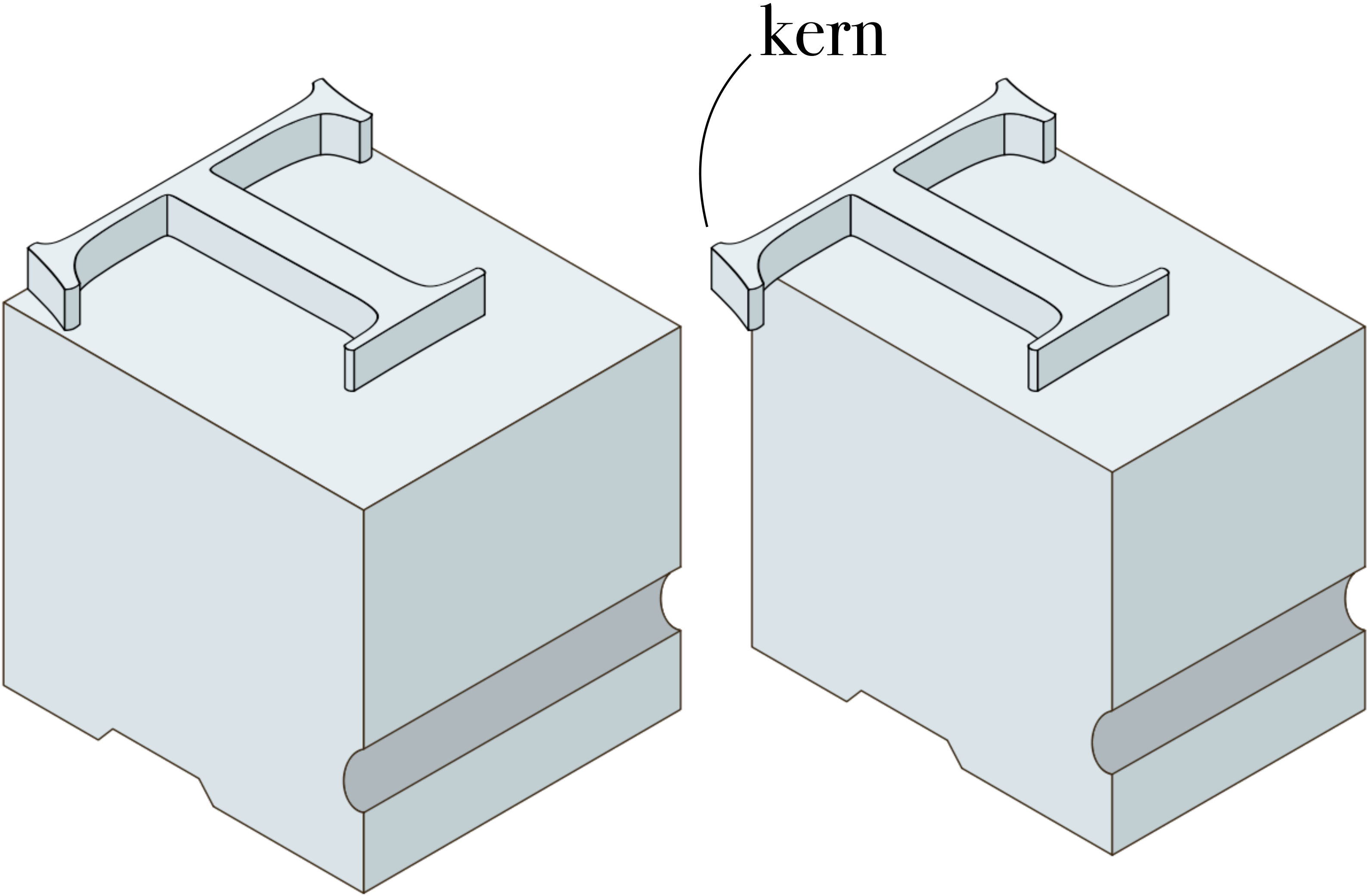



**SMALL CAPS
CAPS TO SMALL CAPS**

kerning

Unterschneidung

zwischen bestimmten
Zeichenpaaren

tracking

letter spacing

character spacing

Spationierung

zwischen allen Zeichen

```
HTML    
CSS    
1 p {  
2   margin: 28vh auto;  
3   font: bold max(4vw, 1em) Raleway;  
4   text-align: center;  
5   text-transform: uppercase;  
6   font-feature-settings: 'kern' 0;  
7 }
```

TALOS IV – TABU

```
HTML    
CSS    
1 p {  
2   margin: 28vh auto;  
3   font: bold max(4vw, 1em) Raleway;  
4   text-align: center;  
5   text-transform: uppercase;  
6   font-feature-settings: 'kern' 1;  
7   letter-spacing: .1em;  
8 }
```

TALOS IV – TABU

```
HTML    
* CSS    
1 p {  
2   margin: 28vh auto;  
3   font: bold max(4vw, 1em) Raleway;  
4   text-align: center;  
5   text-transform: uppercase;  
6   font-feature-settings: 'kern' 1;  
7   letter-spacing: .7em;  
8 }
```

T A L O S I V - T A B U

```
HTML    
* CSS    
1 p {  
2   margin: 28vh auto;  
3   font: bold max(4vw, 1em) Raleway;  
4   text-align: center;  
5   text-transform: uppercase;  
6   font-feature-settings: 'kern' 0;  
7   letter-spacing: .7em;  
8 }
```

T A L O S I V - T A B U

```
HTML
CSS
1 p {
2   font: 10.3vh/12vh Fenice;
3   letter-spacing: -.02em;
4   margin: 0;
5   position: absolute;
6   top: 24.8vh;
7   left: 22.6vh;
8 }
9
10 body {
11   margin: 0;
12   height: 100vh;
13 /* background:
   url(https://2.bp.blogspot.com
   /-i03dWHqsKuY/Ucw2YpUKlOI/AAAAAAAAAFQ
   /NqfUh7pHZZQ/s1456/\66\6F\72\72\65\73
   \74\2D\67\75\6D\70\2D\70\6F\73\74\65
   \72\2D\31\39\39\34\2D\74\6F\6D\2D\68
   \61\6E\6B\73.png) 0/contain no-repeat;
   */
14 }
15
JS
```

The Menagerie



Learn How to Build Accessible Web Apps

with Marcy Sutton

I'm an independent user interface developer and teacher specializing in web accessibility.

Find about [my services](#).

Latest:Writing

[Celebrating One Year of Independence as Modern Sole Design, LLC](#)

[Evinced is Pushing the Limits of Automated Accessibility Testing](#)

[Content-visibility and Accessible Semantics](#)

Latest:Feature

[Testing Accessibility](#)

```
HTML
CSS
1 p {
2   font: 10.3vh/12vh Fenice;
3   letter-spacing: -.03em;
4   margin: 0;
5   position: absolute;
6   top: 24.8vh;
7   left: 62.6vh;
8 }
9
10 body {
11   margin: 0;
12   height: 100vh;
13   background:
14     url(https://2.bp.blogspot.com
15     /-i03dWHqsKuY/Ucw2YpUKlOI/AAAAAAAAAFQ
16     /NqfUh7pHZZQ/s1456/\66\6F\72\72\65\73
17     \74\2D\67\75\6D\70\2D\70\6F\73\74\65
18     \72\2D\31\39\39\34\2D\74\6F\6D\2D\68
19     \61\6E\6B\73.png) 0/contain no-repeat;
20 }
```

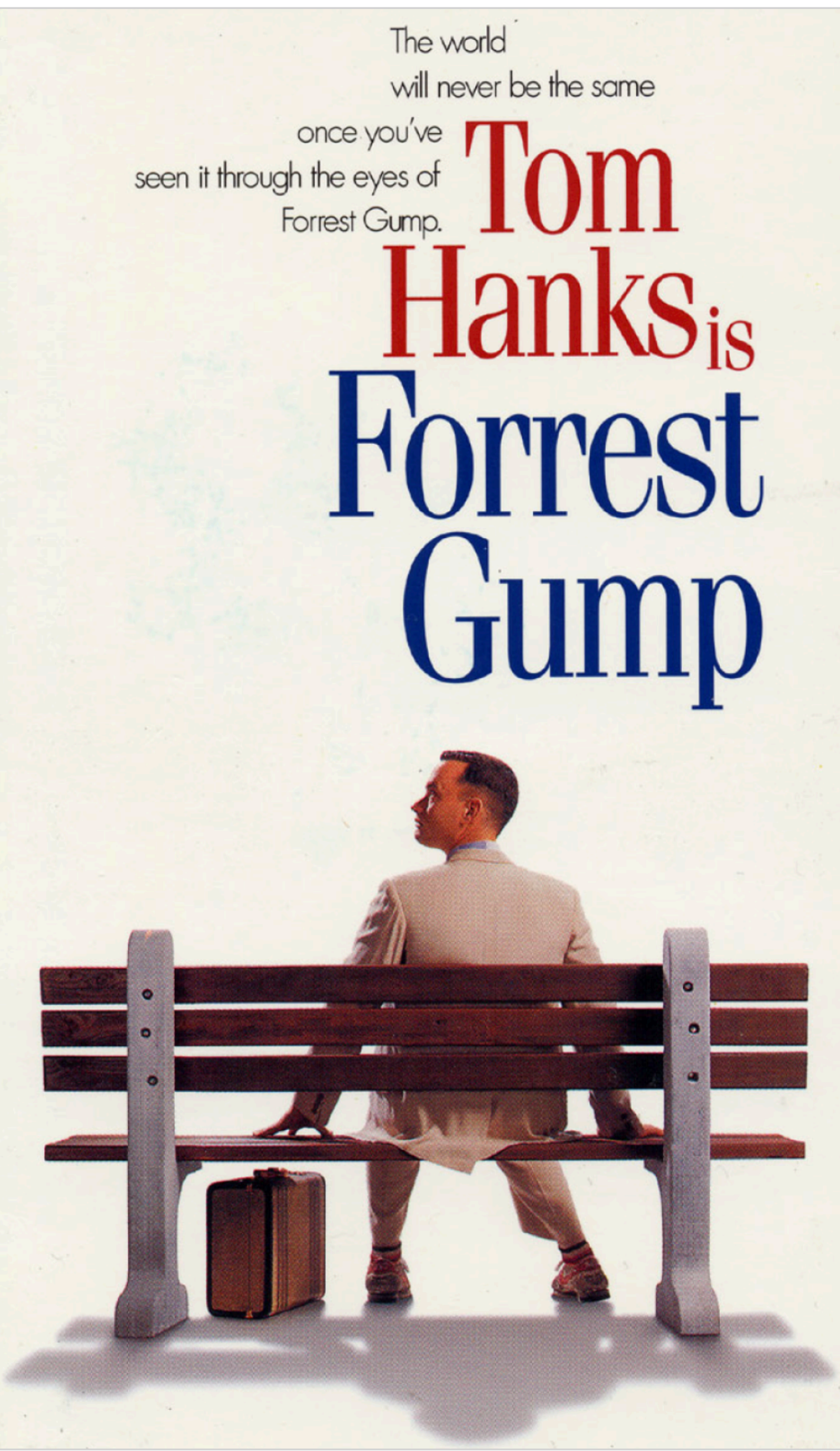



Gunnar Bittersmann
@g16n



Hat der [@espiekermann](#) sich das mit dem Kerning bei Ve so gedacht oder ist das eine Störung bei der [@SBahnBerlin](#)? [#leamtokem](#)

[Translate Tweet](#)



4:00 PM · Jun 18, 2017 · Twitter for iPhone

View Tweet activity



Tweet your reply

Reply



erik spiekermann @espiekermann · Jun 19, 2017



Replying to [@g16n](#) and [@SBahnBerlin](#)

wohl auf dem PC mit Word oder so einem Gurkenprogramm gemacht;
außerdem gibt es DB Sans auch mit Arial Dickten

2



Gunnar Bittersmann @g16n · Jul 6, 2017



Welcome Gurkenprogramm [@DB_Info](#)

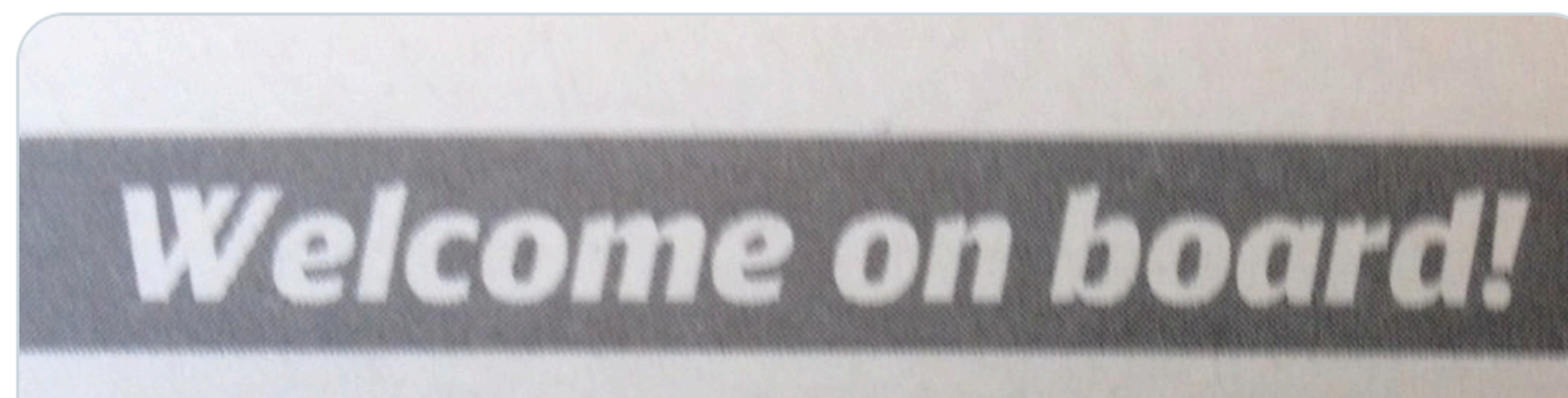



Adrian Roselli
@aardrian



Ugh Slack and its tiny low contrast emoji reaction icons.

I tried to do the upward-pointing finger on a comment from Scott, but chose the middle finger, then removed it and added the thing, and now Slack is telling me I am a “dick to remove”. Which is fair.

Fuck yeah, [#keming](#).

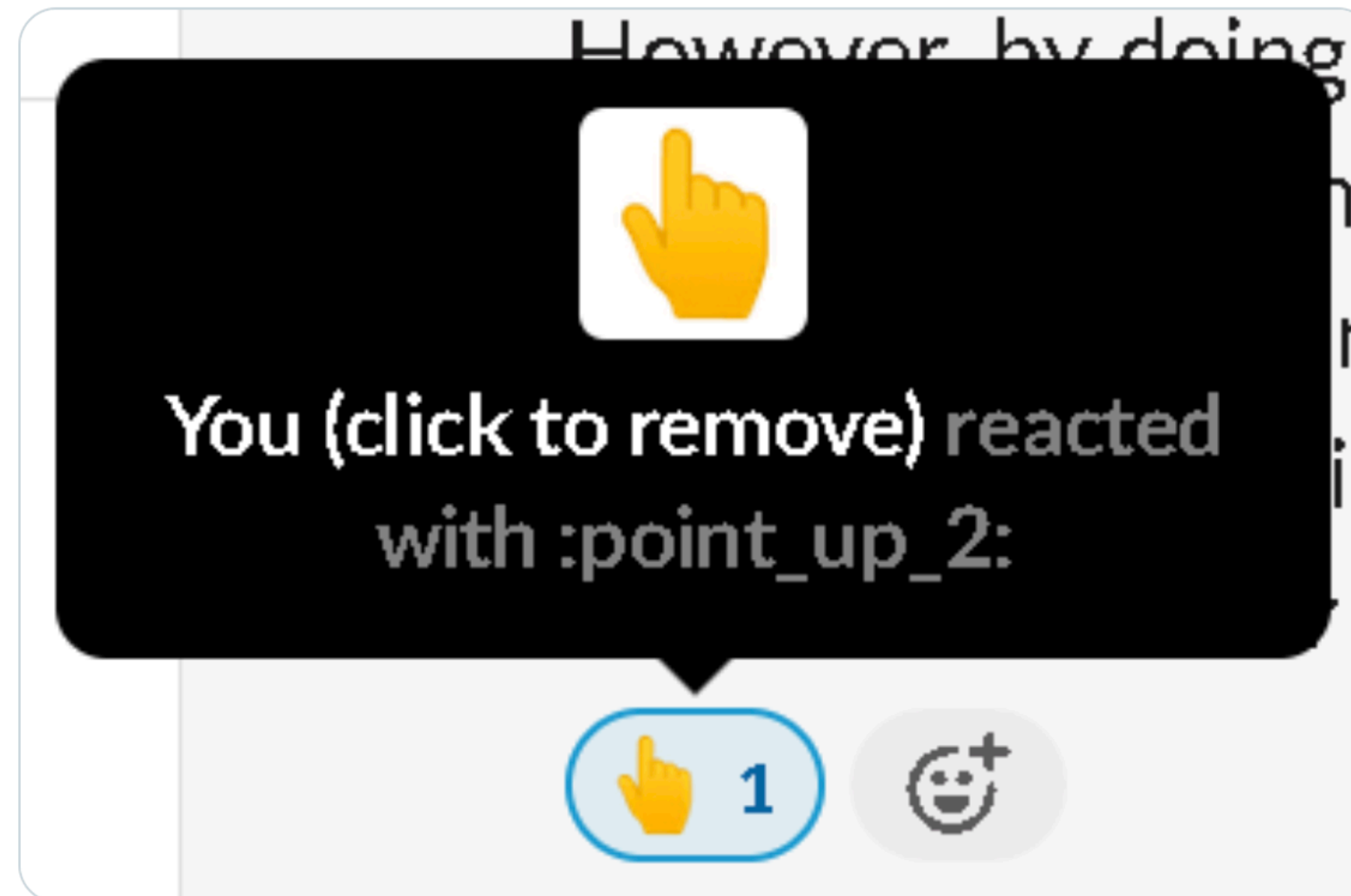

1:52 AM · Oct 1, 2021 · Twitter Web App

7 Likes



learn to kern



kerning
≠
letter spacing



RegExp

≠

regular expression



charset
≠
character set



Don't speak falsely now!

– Jimi Hendrix, *All Along the Watchtower*



Don't speak falsely now!

– Bob Dylan, All Along the Watchtower



There is a whole galaxy out there
full of people who will reach for you.
You have to let them.
Reach for them.

– Michael Burnham to Spock in Star Trek: Discovery S2:E14/S3:E7